

PROBLEM

Solver[™]
BULLETIN

BULLETIN: 25933

Front Wheel Drive Lower Ball Joints

General Motors

PROBLEM:

Premature ball joint wear

- Lateral deflection (side to side) loading causes excessive wear in ball joint.

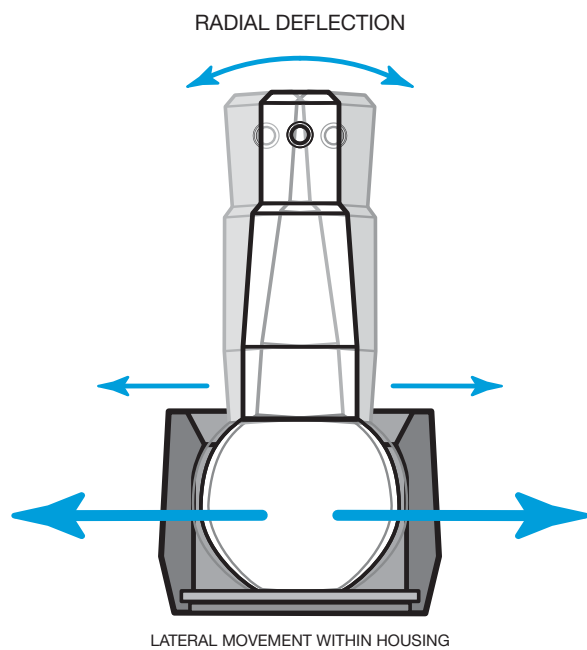

Make / Model / Year	Replacement Part No.
Buick Century 82-96; Skylark 80-85; Chevrolet Celebrity 82-90; Citation 80-85; Chevrolet Truck Lumina APV 90-91; Oldsmobile Cutlass Ciera 82-96; Omega 80-84; Oldsmobile Silhouette 90-91; Pontiac 6000 82-91; Phoenix 80-84; Pontiac Truck Trans Sport 90-91	K5263

SOLUTION:

CARQUEST® improved design K5263



- Utilizes patented CARQUEST® Chassis cover plate design and NASCAR-proven split-bearing technology, which eliminates the excessive radial deflection often experienced with high lateral loads. The ball joint assembly maintains maximum ball-to-bearing contact for greater load carrying capability.
- Belleville washer pre-load provides lower torque and stud articulation with minimal axial clearance.
- Hardened powdered-metal bearings provide a smooth, durable wear surface that extends service life.
- A flange-style sealed boot equipped with a special grease-relief valve keeps contamination out and provides a serviceable sealed environment. (see drawing for Solution)

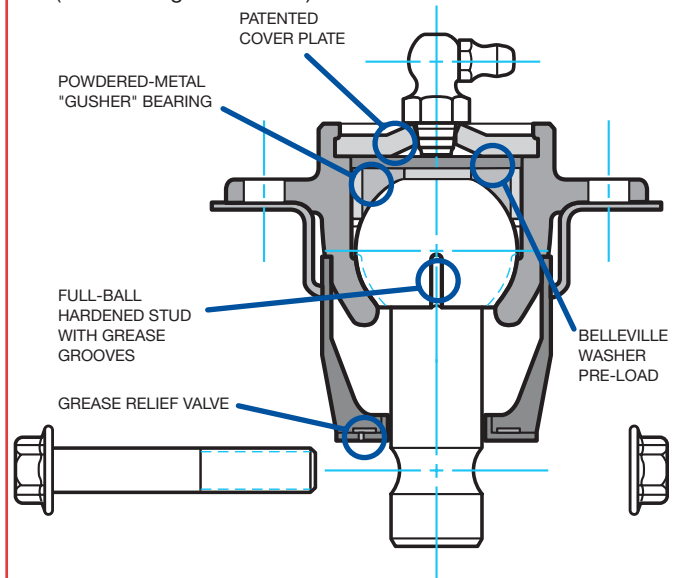

Be Car Care Aware[™]

CARQUEST[®]

MOOG
CHASSIS PARTS
The Problem Solver[™]