



# PROBLEM

# SOLVER

## K7199 REAR STABILIZER LINK KIT CONCORDE, INTREPID, NEW YORKER, VISION

### PROBLEM

The rear suspension stabilizer link on Chrysler Concorde, Intrepid (Canada), LHS, New Yorker, Dodge Intrepid, and Eagle Vision vehicles can seize and break when the rear suspension strut is serviced. The link also uses a one-piece upper bushing which can be difficult to remove and install when servicing struts. The link must be disassembled to service the rear struts.

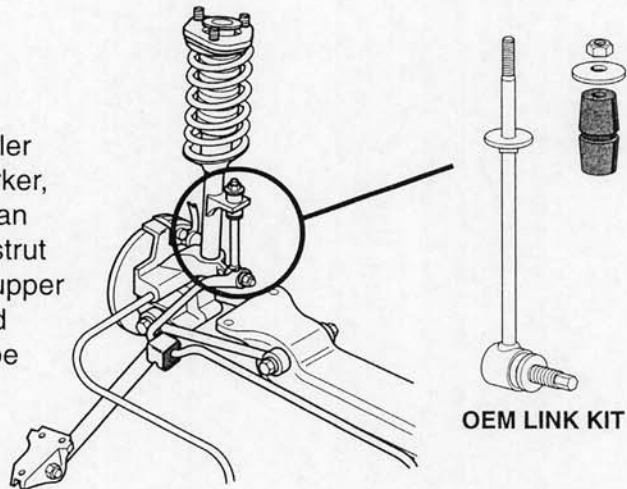

OEM LINK KIT

### SERVICE NOTE

This link uses interference type nuts for attachment. If an air wrench is used for removal/installation purposes, the link can be damaged. The stud in the lower bushing can spin, destroying the bushing.

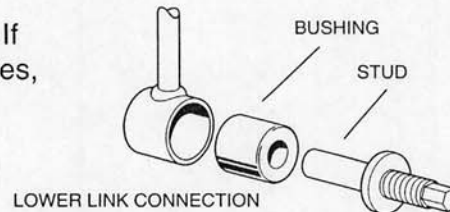

LOWER LINK CONNECTION

### SOLUTION

The Moog Problem Solver K7199 stabilizer link kit features a two piece bushing to ease installation. These bushings are also of a urethane material for extended service life.

### APPLICATION

1996-93	Chrysler Concorde
1996-94	Chrysler LHS and New Yorker
1996-93	Chrysler Intrepid (Canada)
1996-93	Dodge Intrepid
1996-93	Eagle Vision

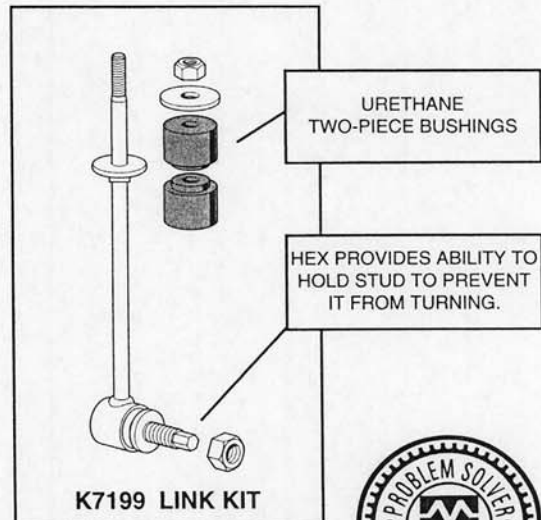

K7199 LINK KIT

