

Bulletin

ServiceLinkSM



Bulletin SL 9-91
© 1991 Moog Automotive, Inc.

SERVICE TIPS FOR THE PROFESSIONAL TECHNICIAN

4 X 4 BALL JOINT INSTALLATION

IMPROPER INSTALLATION CAN CAUSE STEERING PROBLEMS AND PREMATURE BALL JOINT FAILURE

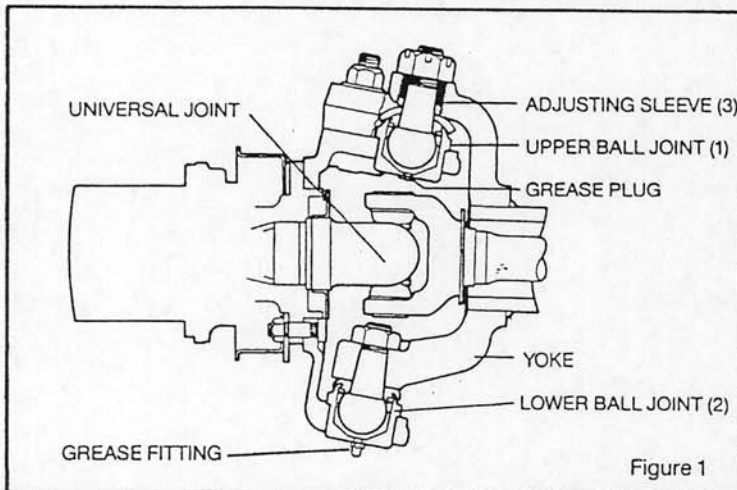

On this type axle, upper (1) and lower (2) ball joints are load carriers. To ensure that the load is properly distributed an adjustment sleeve (3) is used, in conjunction with the upper ball joint. (Fig. 1)

TORQUE SEQUENCE	TORQUE
1. Lower Ball Joint	70 Foot Pounds
2. Adjusting Sleeve	70 Foot Pounds
3. Upper Ball Joint	100 Foot Pounds

NOTE: Clean threads before installing new sleeve. Threads must be clean or torque accuracy will be affected.

CAUTION: The use of certain aftermarket alignment bushings (adjusting sleeves) may cause high spindle torque, resulting in poor handling and damage to the upper ball joint.

Improper tightening or backing off the adjustment sleeve can cause tight steering which can cause steering wander. Improper loading of ball joints can also occur, causing premature ball joint failure.

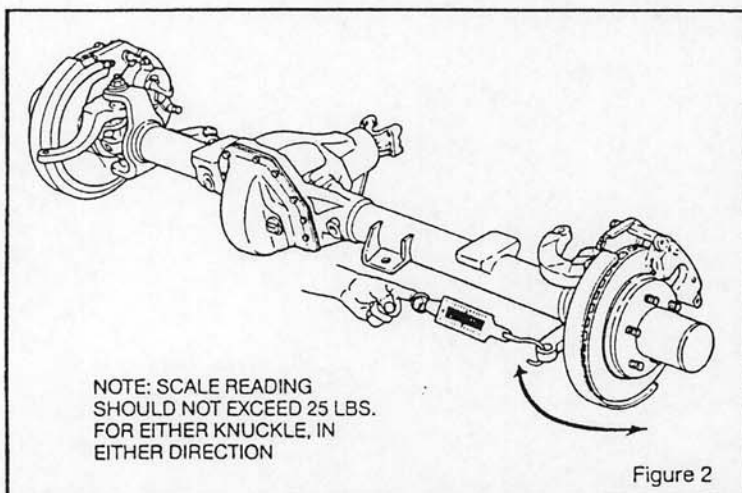

After ball joint installation, check steering effort with a pullscale. If reading is high, above 25 lbs, break tapers, and disassemble. Check ball joints for looseness. If not loose reassemble and torque to specification. (Fig. 2)

SEE REVERSE SIDE

IMPROPER INSTALLATION

RESULT: HARD STEERING, COMPONENT FAILURE

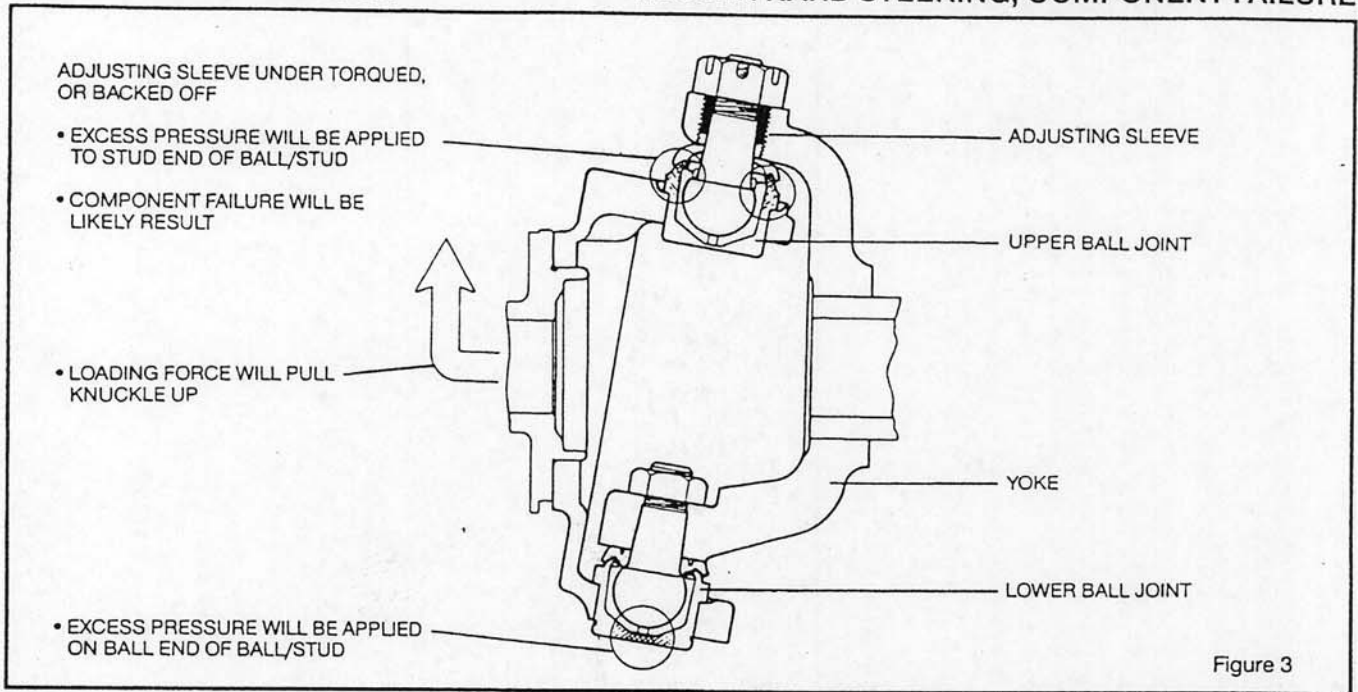

The improper installation shown above or hard steering complaints can be minimized by checking spindle tightness as shown in Fig 2.

If a pullscale is not available, a beam or dial type torque wrench can be used as a substitute. Install a standard bolt and flat washers into the tie rod taper as shown. (Fig 4)

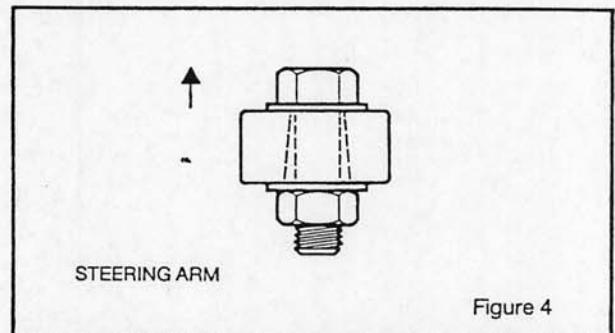

The torque reading should not exceed 105 inch pounds. It is very important that the torque wrench be positioned as shown or accuracy will be greatly reduced. (Fig 5)

