



TECHNICAL SERVICE BULLETIN

NO. 2005

APPLICATION

1994-1997 Ford Probe, Mazda MX3 with 4 cyl. & A/T
1994-2000 Mazda 626 with 4 cyl. & A/T
1998-2000 Mazda 626 with 6 cyl. & A/T
1995-2000 Ford Contour/Mercury Mystique with 6 cyl. & A/T
1999-2001 Mercury Cougar with A/T

PART NUMBERS

4059
4359
4227
4427

SUBJECT

Vehicles with the Ford CD4E automatic transmission.

CONDITION

The driver's side front CV axle has a 6-1/2 inch male inboard stub that fits into the transmission's side gear. On the stub next to the housing seal surface is a carrier support surface that fits into the final drive sun gear inside the transmission (see figure 1). This sprocket assembly is chain driven with the reverse/overdrive sprocket by the planetary gear sets (see figure 2). The final drive sprocket assembly rides on the axle stub carrier support surface using a pressed, center bored bushing. This bushing wears the carrier support surface causing damage to the axle and eventually the transmission.

SOLUTION

If the carrier support surface of the axle being replaced appears rough and worn, then several possible failures need to be checked before replacing the axle or premature failure of the axle or possible damage to the transmission could occur. If the transmission's internal oiling solenoid that lubricates this bushing fails, then the 2nd and 3rd gearshifts will not function. Although the Aftermarket lists this bushing, no tool exists to replace it. Ford only offer the bushing in a complete sprocket assembly making its replacement a very costly repair.

The most common contributor to premature wear of this bushing is the vehicle not being within proper alignment specs. Without a four-wheel alignment, even though the front wheels may be centered to the rack, the rear thrust is pushing the front wheels causing stress on the front CV joints. The thrust forces acting on the front wheels while driving changes ALL the alignment specs resulting in the front wheels being in a constant turning action. This will wear the side gears and transmission seals as well as stressing this bushing. Another possible sign that alignment is affecting these items is a worn or torn inboard boot. Do not forget that worn motor mounts will also affect alignment thrust forces.

© TECH BULLETIN SUPPLIED BY:



TOLL FREE TECH LINE (888) 726-2234

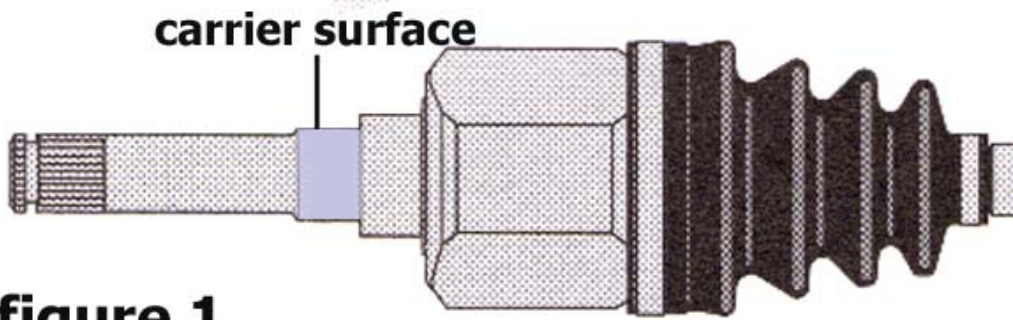

figure 1

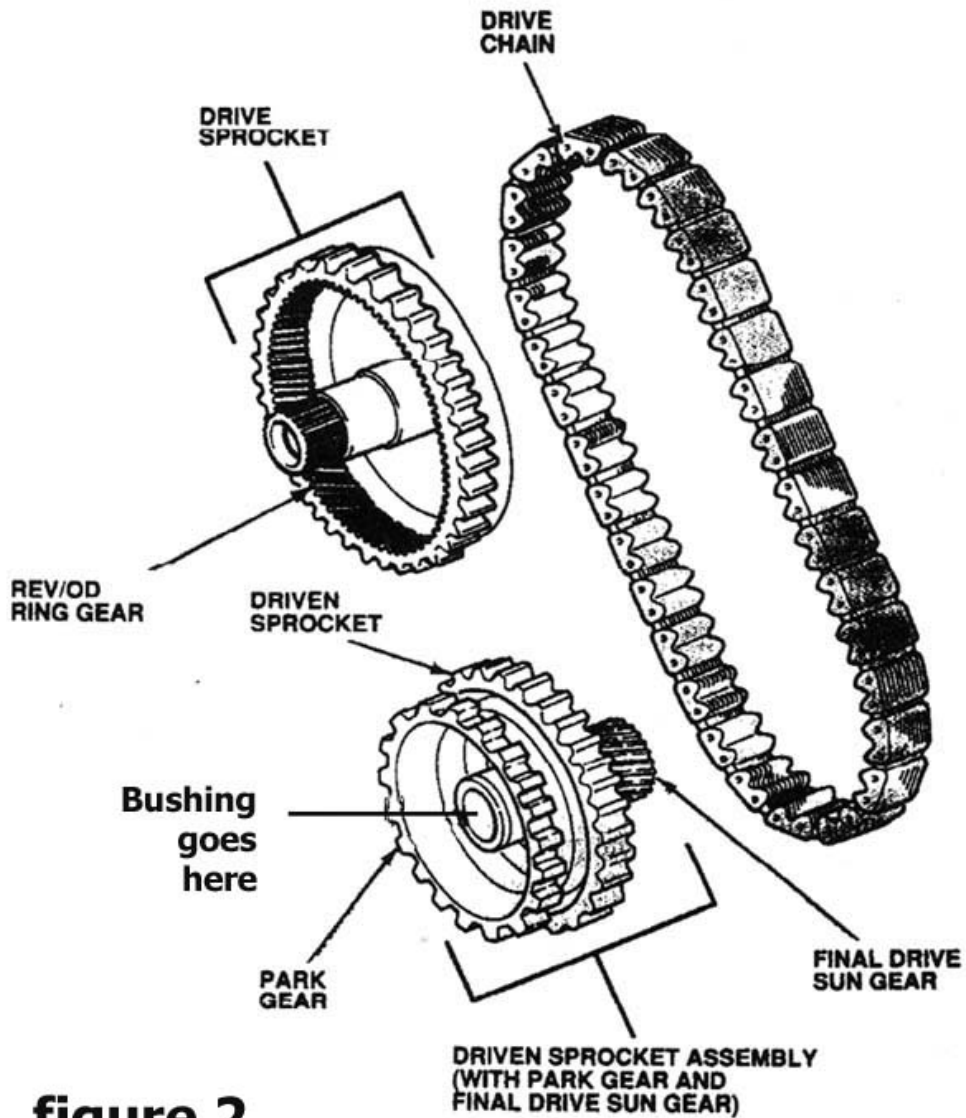

figure 2

© TECH BULLETIN SUPPLIED BY:



American Remanufacturers, Inc.

TOLL FREE TECH LINE (888) 726-2234