

PRODUCT SPOTLIGHT

No Bearing “NB” Concentric Slave Cylinders

In order to eliminate the duplicate cost of sourcing two release bearings when replacing the clutch kit and concentric slave cylinder (CSC), Carquest offers the industry’s most comprehensive lineup of NB (no bearing) CSC’s.

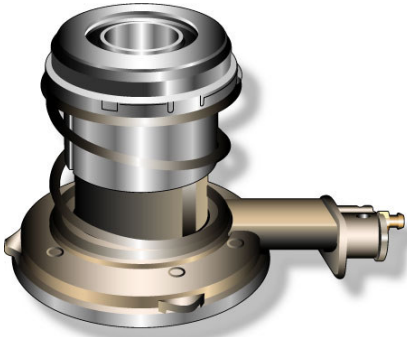

**Concentric Slave
Cylinder
(With Bearing)**

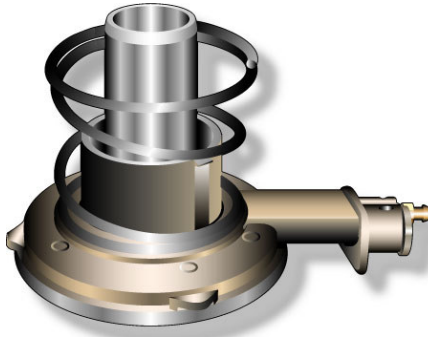

**Concentric Slave
Cylinder
(No Bearing)**

Since their introduction in light truck applications in the late 1980’s, clutch release systems containing a CSC have become the hydraulic system of choice among domestic applications. Not only are they reliable and easy to troubleshoot, they also eliminate the need for other parts such as the release fork, quill, and pivot linkage.

Some CSC’s are equipped with a replaceable release bearing. The thrust face surface of this bearing maintains constant contact with the pressure plate diaphragm spring. As a result of this contact, the bearing may fail before the remainder of the CSC.

When installing a new clutch kit in a CSC equipped application, always inspect the hydraulic system. If it is operating properly, replace the old release bearing with a new release bearing (contained in the clutch kit), along with the other components found in the kit.

If the clutch will not release and/or the hydraulic system is leaking or won’t bleed properly, install a new CSC (“no bearing” version), master cylinder, and clutch kit. The new release bearing contained in the kit should be installed on the new “no bearing” CSC.

“NB” Concentric Slave Cylinder Options

Part Number	Application
S0418NB	1996 - 2002 GM car/truck
S0419NB	1997 - 2002 5.7L Chevrolet Corvette
S0421NB	2002 - 2004 GM truck
S0422NB	2001 - 2002 GM truck
S0423NB	2003 - 2004 GM truck
S0536NB	1992 - 2002 Dodge Viper
S0706NB	1985 -1988 Ford truck
S0707NB	1988 - 1995 Ford/Mazda car/truck
S0710NB	1993 - 2002 Ford/Mazda car/truck
S0723NB	2001 - 2003 Ford truck

For more details please contact our technical service department at 800.528.6743.



TECHNICAL BULLETIN

IMPORTANT INSTALLATION INFORMATION!

This bulletin contains specific instructions designed to ensure proper installation. Please don't hesitate to call **800.528.6743** for expert technical assistance.

