



TechPro

Bulletin

GM PASS KEY SYSTEMS QUICK TESTS

Since the 1986 model year, GM has used the Pass Key system as an anti-theft device. It started using this system on the 1986 Corvette, and in 1988 added this system to the Camaro and Firebird models. Since that time, GM has added this system to many of its models.

This system has two functions: first, it has a starter interrupt feature; second, it can disable the fuel injectors electronically if the ECM does not receive the correct signal from the Pass Key system. The Pass Key system consists of four components, they are:

- 1) The Ignition Key: This is a special key with a resistor pellet on it. There are 15 different key blanks of this type, each with a different resistance value (refer to Table #1).
- 2) The Ignition Lock Cylinder: This cylinder looks and functions like a conventional lock cylinder, except for a set of contacts for the resistor pellet, and a pair of leads which connect to the vehicle's wiring harness.
- 3) The Pass Key Decoder Module: This solid state component checks for the correct key resistance value so that the vehicle can be started.
- 4) The Starter Enable Relay: This relay is connected between the ignition switch and the starter solenoid. It allows battery power to the starter solenoid when the Decoder Module energizes it.

If a vehicle is experiencing a "No Crank" condition because the Pass Key

decoder module is not sending the "OK to start" signal to the ECM, here are a few tips to help diagnose this system. First, look for a flashing or illuminated "Security" light. This is an indication that the Pass Key system is disabling the starter. Remember, even if you supply power to the starter solenoid, the vehicle will not start, because the ECM will shut down the fuel injectors until it gets the proper signal from the Decoder Module. The

most likely component to fail is the ignition lock cylinder. First, make sure that the ignition key is not damaged, or missing its pellet. Second, measure the resistance across the ends of the key pellet. You should have a resistance value close to one of the values listed on Table #1. Next, locate either a 2 wire connector at the base of the steering column, or a 48 wire connector under the dash. If you have a 2 pin connector, which is usually orange (don't confuse the yellow air bag connector for the lock cylinder connector), disconnect it. Now, insert the ignition key and turn the key to the "Start" position while measuring the resistance across the two wire connector leading up the steering column. The resistance reading should match the key resistance throughout the entire range of lock cylinder rotation. Any change in the resistance reading during key rotation will cause a no start situation. If you have the 48 wire

PassKey Codes and Resistance Values			
Key Code	Nominal Resistance	Low Range	High Range
1	402 Ω	386Ω	438Ω
2	523 Ω	502Ω	564Ω
3	681 Ω	654Ω	728Ω
4	887 Ω	852Ω	942Ω
5	1130 Ω	1085Ω	1195Ω
6	1470 Ω	1411Ω	1549Ω
7	1870 Ω	1795Ω	1965Ω
8	2370 Ω	2275Ω	2485Ω
9	3010 Ω	2890Ω	3150Ω
10	3740 Ω	3590Ω	3910Ω
11	4750 Ω	4560Ω	4960Ω
12	6040 Ω	5798Ω	6302Ω
13	7500 Ω	7200Ω	7820Ω
14	9530 Ω	9149Ω	9931Ω
15	11800 Ω	11328Ω	12292Ω

Table #1

pen to be the last two terminals in row "E". As before, if the ohmmeter indicates a change in the resistance reading, the lock cylinder must be replaced.

Another method in diagnosing this system is by checking the voltage from the Decoder Module to the lock cylinder. Normally the Decoder Module output is approximately 5 volts. The resistance of the key will drop this voltage to a certain value. If you see a constant 5 volts while back probing this circuit when the key is turned, or any large change in the voltage reading, this indicates that the cylinder needs to be replaced. Any of the other components in the Pass Key system can fail, however, the lock cylinder is usually the cause of most problems.

Pat Sugar—Top Gun Technician

GM 6.5L DIESEL ENG.-NO START

This tip applies to the 1994 and newer version that has the computer controlled diesel fuel injection system. Thankfully, this system is not nearly as complicated as some other systems being used. This means that there are a few quick checks that any technician can perform in order to determine why there's a no-start condition. The computer in this system uses two sensors to determine engine rotation.

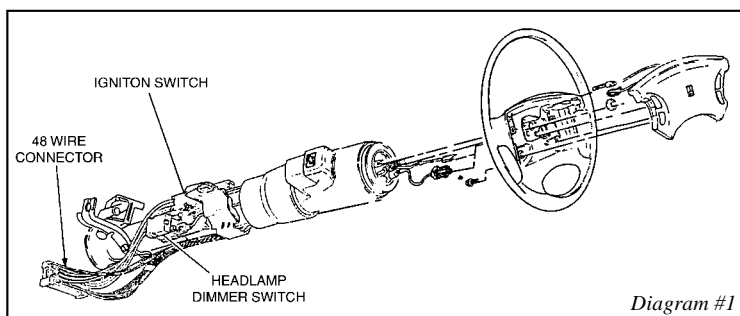
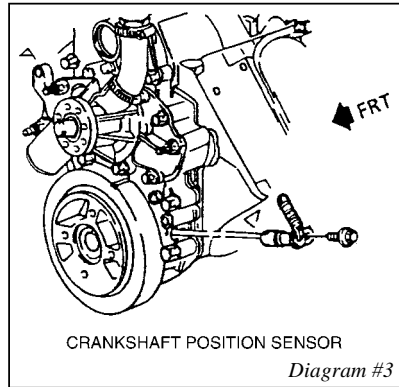
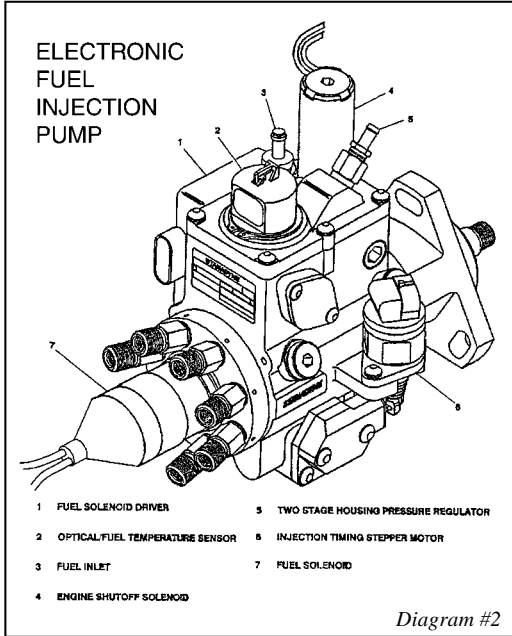

Diagram #1



If you run across one of these vehicles that is a "no-start", before you do any testing, make sure the batteries are fully charged and are in good condition. The engine must be mechanically sound. The starting system should be fully operational. Also, make sure the "Service Engine Soon" light is operational. No light indicates a power problem to the computer that must be resolved before going any further. Once you have verified that the light is operational, make sure there are no trouble codes. Now that the preliminary steps are out of the way, the first quick check is to disconnect the optical pickup at the pump. Turn the key on, wait for the "wait" light to go off. Now crank the engine for approximately 30 seconds. If the engine starts, the most likely cause of the no start is probably an erratic optical sensor signal, as the computer was able to run the engine based solely on the input of the crankshaft position sensor. If it does not start, reconnect the optical sensor and disconnect the crankshaft sensor. Repeat the starting procedure as before. If the vehicle starts, the problem again is an erratic crank signal. Keep in mind that a signal that is completely missing from one of the sensors will not cause a no start condition,

simply because it relies upon input from the other sensor. When this happens, it operates in "back up" strategy. In a situation where an erratic signal is present, the computer becomes confused, resulting in a no

start. If disconnecting the sensors does not yield any result, make sure there's available fuel at the pump. Also, check to see if there's an injection command from the fuel solenoid driver (this will usually trip a fault code 35 or 36). If not, make sure there is a command from the computer to the driver. You can do this by making sure there's at least 1.2 volts DC at terminal "A" of the fuel solenoid driver while cranking. If not, check for battery voltage at terminal C of the driver harness connector with the key "on" (refer to diagram #4). If all checks are good, the pump itself needs to be checked. If you determine that the computer requires replacement, you must program the "TDC offset" into the new computer. This process electronically compensates for minor timing differences between the injection pump and the crankshaft. The vehicle must be at operating temperature and at idle. This can only be accomplished with a scan tool. So, just make sure you have a scan tool that has this ability before you replace that computer. Failure to set the "TDC offset" may not prevent the vehicle from starting, but it could cause some driveability problems. If the computer wasn't the problem, make sure to clear the codes that may have tripped due to testing, before the vehicle leaves the shop.

Jeff Auerbach—Domestic Specialist

FORD- IDM FAULT CODES AFTER MODULE REPLACEMENT

If you run across a Ford vehicle that has an IDM (Ignition Diagnostic Monitor) fault code, this tip may be helpful.

The TFI module (Thick Film Integration, which refers to the type of internal circuitry used in this module) has been used on the EEC-IV system since its inception. There are two different module types, and, even though they may look alike, they are not interchangeable.

One type is referred to as the "Push Start" type, while the other is called the "CCD" (Computer Controlled Dwell) type. The "Push Start" module gets its name from the 4th pin on the module connector, which is a start signal input

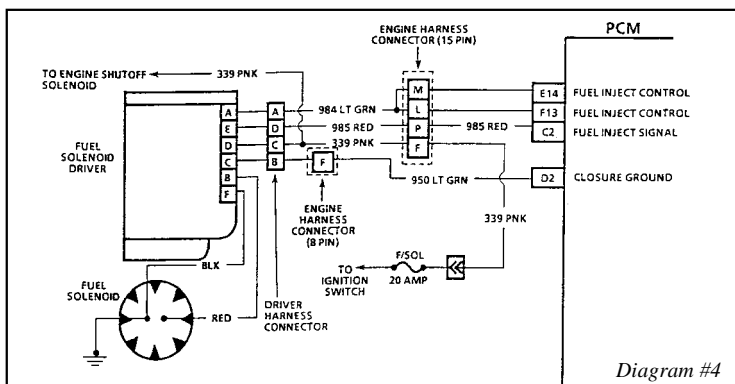

These sensors are in two locations. The first sensor is an optical sensor which is located inside of the injection pump (refer to diagram #2). This sensor produces two signals which are identical to the signals generated by an optical distributor in gasoline powered engines. One signal is relatively slow, producing eight signal pulses per revolution of the pump shaft, or, one for each cylinder. One of these signal pulses is longer than the other seven in order for the computer to identify cylinder #1. The second signal is a much faster signal, producing 512 signal pulses per pump shaft revolution. This sensor also contains a fuel temperature sensor.

The second sensor, the crankshaft position sensor, is a Hall effect type sensor mounted through the front timing cover which produces four signal pulses per turn of the crankshaft, or, eight pulses per turn of the pump shaft (refer to diagram #3).

from the starting system. When the module receives this 12 volt input, it increases or "Pushes" the ignition coil dwell for maximum coil output for easier starting. The "CCD" module does not use a start signal input, but does rely upon the ECM Spout input to control ignition coil primary dwell. By the way, ECM Spout controls ignition timing on both module systems.

Under normal running conditions, the "Push Start" module starts the ignition coil primary dwell time about 3.5 milliseconds before then next anticipated coil firing. At this point the module is waiting to see the Spout signal voltage change from low to high. When this happens, current flow to the coil is stopped, which will result in the coil firing. If the time is longer than 3.5 milliseconds, the module will reduce the primary current to prevent the coil from overheating, since it cannot anticipate the next coil firing. The "CCD" module relies solely on the ECM Spout input to change ignition coil primary dwell time. On this system, the trailing edge of the Spout wave will start the primary cycle, while the leading edge of the next wave will end it, resulting in the coil firing. The time in between signals is the dwell.

Both modules are used in systems where they may be mounted on the distributor, or, they may be remotely mounted away from the distributor (commonly called "Closed Bowl" versions). Usually, the "Push Start" modules are gray in color, while the "CCD" modules are black.

IDM is a feedback signal generated by the ignition system and is monitored at pin #4 of the ECM. Its purpose is to diagnose missed ignition primary pulses at the time the ECM commands the Spout signal to fire the coil. Since it is used solely for diagnostic purposes, if this circuit is not operating properly, it will not affect vehicle driveability.

Both "Push Start" and "CCD" systems produce an "IDM" signal, however, they do it in different ways. The "Push Start" system uses an external 22K ohm resistor (22,000 ohms) that is usually taped to the wiring harness that is connected to the negative terminal of the ignition coil. This resistor is used to lower the voltage of the Tach signal being supplied to pin #4 of the ECM. This external resistor is not used on the CCD system since it is part of the internal circuitry of the module, which produces the IDM signal. So, the IDM

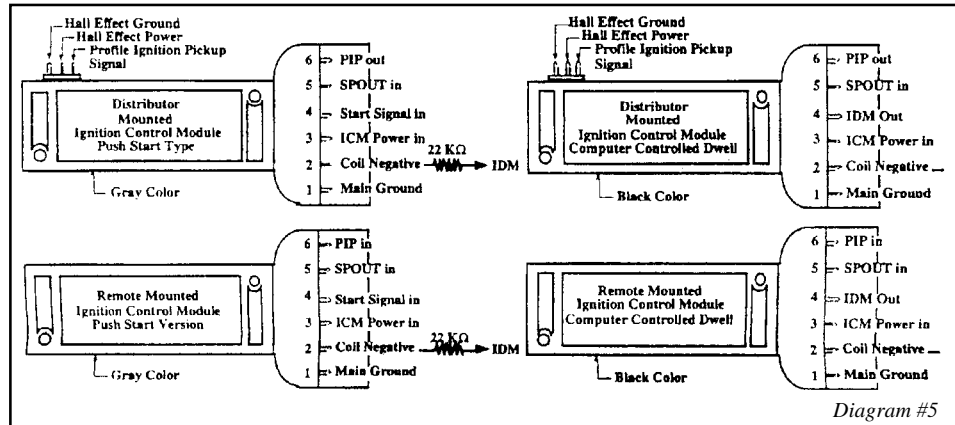

signal travels from pin #4 of the module directly to pin #4 of the ECM.

Oddly enough, the "Start" pin on the "Push Start" module is the same pin as the IDM pin on the "CCD" module. While the connectors are identical, interchanging the modules may or may not create a driveability problem, while tripping a fault code of #18, or # 212 (IDM code). These are problems consistent with interchanging one type module in place of the other.

Identifying the correct module for your vehicle can be accomplished in a number of ways. First, always refer to the correct application in the Engine Management catalog. If that information is not available, check the wiring of the vehicle. If pin # 4 of the module gets a start signal (which should be battery voltage) from the starter circuit, it's a "Push Start" system. On the other hand, if pin #4 of the module is wired directly to pin #4 of the ECM, then it's a CCD system (refer to diagram #5).

James D'Anna—Top Gun Technician

FORD VEHICLES- IDLE PROBLEMS

Ford vehicles with an Idle Air Control Motor (called IAC) that have idle problems and sometimes noise concerns can be diagnosed in the following manner. For high idle problems, try unplugging the IAC motor. If the idle drops, it's usually due to an input signal to the computer which results in the computer raising the idle speed. If this is the case, look at all of the computer inputs to make sure everything is up to par. If the engine RPM does not drop when the IAC motor is disconnected, then either the IAC motor is not functioning properly, or, there is a

vacuum leak in the engine. Stop the engine, remove the IAC motor and block off the passages. Restart the engine to see if there is any change in engine RPM. An idle speed higher than base idle specs indicates a vacuum leak. If the engine RPM is at base idle specs, then the IAC motor is bad. Resistance specs are 7-13 ohms. A good resistance reading does not necessarily mean that the IAC motor is good. Occasionally, an IAC motor will become weak, and will actually bypass too much air, causing a high idle condition even though everything else is operating properly.

Diagnosing an IAC motor and its circuit is fairly easy. This motor uses a two wire connector. One wire supplies power, while the other wire is a computer controlled ground. The computer controls the IAC motor by pulsing the ground wire, or, duty cycling it to ground in order to achieve the proper idle speed. In diagnosing this circuit, start by checking for battery voltage (with the ignition key "On") on the red wire by back probing the connector using a digital voltmeter connected to a good ground. Next, check the other wire which usually has a stripe on it. This is the control side of the circuit. With the ignition key "On", engine not running, you should measure battery voltage on this wire. When the engine is running, you should notice a voltage change. Typical operating temperature, normal idle voltage should be approximately between 9 to 10.5 volts DC. This equates to a 30% duty cycle. Cold engine readings should reveal a lower voltage reading with a higher duty cycle. Typical duty cycle for most applications should be 28-34%. As duty cycle increases, so should the idle speed increase.

Remember, the value you see on your

Continued on next page...

scan tool for IAC% is actually the computer's command to the IAC, not necessarily the actual IAC reading, especially if there is a problem. Under normal conditions, the reading should agree.

If you see a very high duty cycle or low voltage, and the idle speed is normal or lower than normal, this indicates that the computer is trying to maintain a good idle by overcompensating. This may be due to a faulty or "lazy" IAC motor.

If the vehicle exhibits poor cold starting, or low idle problems, try grounding the control side of the circuit and look for an immediate reaction. When you ground the control side, you are simulating a computer command of 100% duty cycle, which should result in an immediate idle change to approximately 2000 RPM. If the response is slow, or, there is no change at all, then either the IAC is faulty or very dirty.

The EEC IV "Key On, Engine Running" self-test includes an idle speed test. When this test is initiated, the computer will momentarily unground the IAC motor and then set it to a fixed point. This is done to verify the base engine idle speed and the ability to control idle speed. If the computer detects a problem, it will set at least one of four idle related fault codes that will help us identify the problem. Always make sure that ignition base timing is correct when performing diagnostics for an idle control problem. Finally, never assume that a "good" used part is an acceptable replacement part. Even though it may function, it may not match the application, creating the possibility of additional problems.

Mike Nieto-Ford Specialist

IGNITION SWITCH PROBLEMS- ALL VEHICLES

There have been a number of customers that have experienced a problem with an ignition switch after recent replacement. Symptoms usually include binding, sticking, or just usually hard to operate. This usually results in the replacement of the switch, and in some cases, the lock cylinder is also replaced. Please keep in mind that this problem can be easily avoided by lubricating the ignition switch BEFORE

installation. All it takes is a little white grease on the mechanism, and the problem disappears. Lock cylinder problems can also be eliminated by using liquid graphite on the key just before inserting it into the cylinder. After the key is installed, rotate the key through all of the positions in order to properly distribute the lubricant. Keep in mind that all of the lubricant in the world will not make up for an improperly installed switch. Proper switch alignment, as well as mounting screw torque, will assure proper switch operation throughout its life, and at the same time, keep the customer from returning with a complaint about the switch that was recently replaced.

Bob Reuther-Technical Support

GENERAL MOTORS TRUCK & VANS W/ THROTTLE BODY INJECTION-5.7L HEAVY DUTY, 7.4L ENGS. - KEEP RUNNING WHEN THE KEY IS OFF

These vehicles may exhibit this symptom intermittently, or it may be a consistent problem. The problem may be the Hot Fuel Handling Module. This module is usually located near the ECM. Its purpose is to extend the normal two second fuel pump prime to twenty seconds in order to eliminate vapor lock during high temperature operation. This module has three wires. The first wire is a black wire with a white stripe, which is a ground. The second wire is usually a pink wire with a black stripe. This wire supplies battery power while the key is in the "On" position through the gauge fuse. The third wire is either: tan, tan with a white stripe, or

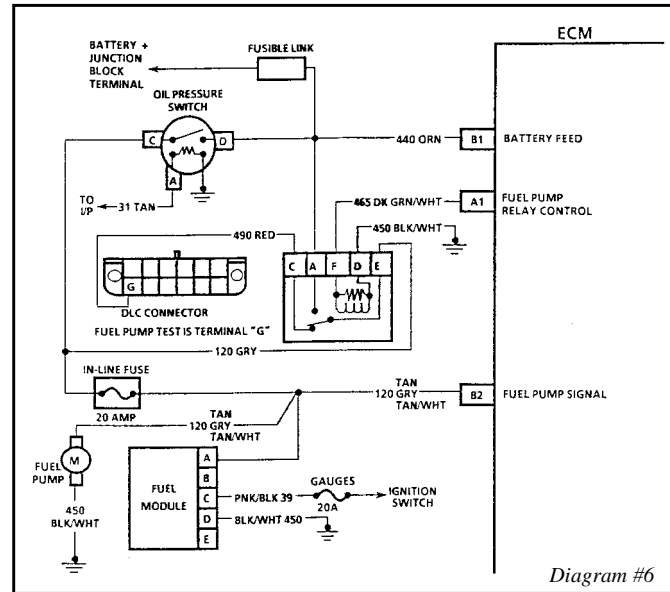

gray, which leads to the fuel pump (refer to diagram #6).

What happens to create this problem is that when the ignition key is turned off, the fuel module will create a short from the pink wire to the tan or gray wire. When this happens, power is supplied backward through the gauge fuse. In this situation, not only does the fuel pump run, every thing that's connected to that tan or gray wire will receive power. The result: the vehicle keeps running. A quick way to check this is to remove the gauge fuse to see if the vehicle shuts off. If it does, you've discovered the problem. Not all vehicles equipped with the 5.7L engines are equipped with the fuel control module. Only those that are considered for heavy-duty use receive this feature.

John Rogers-Domestic Specialist

GM CARS W/ 3.1L ENG. - ENGINE MISFIRE

You run across a GM vehicle with a 3.1L engine that exhibits a misfire, and your diagnosis leads you to an injector not working. Before you proceed any further with your diagnostics, check the 10-way injector connector that's located right behind the alternator. It seems that this harness has a tendency to rub against either a bracket or the power steering line, creating a problem with one or more injectors which leads to a lean misfire.

Joe Dantuono-GM specialist